

**SHEET LIST**

ARCHITECTURE	CIVIL	LANDSCAPE
A00 COVER SHEET	C1 .....	L1 .....
A02 PERSPECTIVES		
A10 SITE PLAN - EXISTING		
A11 SUBDIVISION PLAN		
A12 SITE PLAN - PROPOSED		
A13 FIRE-TRUCK TURNING PLAN		
A14 REFUSE COLLECTION TRUCK TURNING PLAN		
A15 TRUCK TURNING PLAN		
A16 SITE DETAILS		
A21 MAIN FLOOR		
A22 SECOND FLOOR		
A23 ROOF PLAN		
A31 BUILDING ELEVATIONS		
A32 BUILDING SECTIONS		

**PROJECT TEAM**

**ARCHITECT of RECORD**

CRAIG MITCHELL | ARCHITECTURE+DESIGN INC.  
327 KEARY STREET  
NEW WESTMINSTER, BC V3L 3L2  
PHONE: 778.772.8332  
EMAIL: cma@cmad.ca  
PRINCIPAL IN CHARGE: CRAIG MITCHELL

**BUILDING CODE**

KRAHN ENGINEERING LTD.  
#100 - 2990 VIRTUAL WAY  
VANCOUVER, BC V5S 0C4  
PHONE: 604.294.8662  
EMAIL: SCOTT@KRAHN.COM  
PROJECT MANAGER: SCOTT DELGATTY

**DEVELOPER**

BEEDIE  
3030 GILMORE DIVERSION  
BURNABY, BC V5G 3B4  
PHONE: 604.453.3321  
EMAIL: CONNER.OLEARY@BEEDIE.CA  
PRINCIPAL IN CHARGE: CONNER O'LEARY

**CIVIL**

BINNIE & ASSOCIATES LTD.  
4940 CANADA WAY  
BURNABY, BC V5G 4M5  
PHONE: 778.945.6047  
EMAIL: BGILMORE@BINNIE.COM  
PRINCIPAL IN CHARGE: BRAD GILMORE

**SURVEY**

TARGET LAND SURVEYING LTD.  
#101 - 1061 RIDGEWAY AVENUE  
COQUITLAM, BC V3J 1S6  
PHONE: 604.936.6151  
PRINCIPAL IN CHARGE: CRAIG NAKAMURA

**LANDSCAPE**

LANDSPACE DESIGN INC.  
142 GARDEN DRIVE  
VANCOUVER, BC V5L 4P4  
PHONE: 604.252.9500  
EMAIL: LANDSCAPE@TELUS.NET  
PRINCIPAL IN CHARGE: AL TANZER





**NORTH-WEST CORNER VIEW**



**NORTH-EAST CORNER VIEW**



**SOUTH-WEST CORNER VIEW**



**SOUTH-EAST CORNER VIEW**

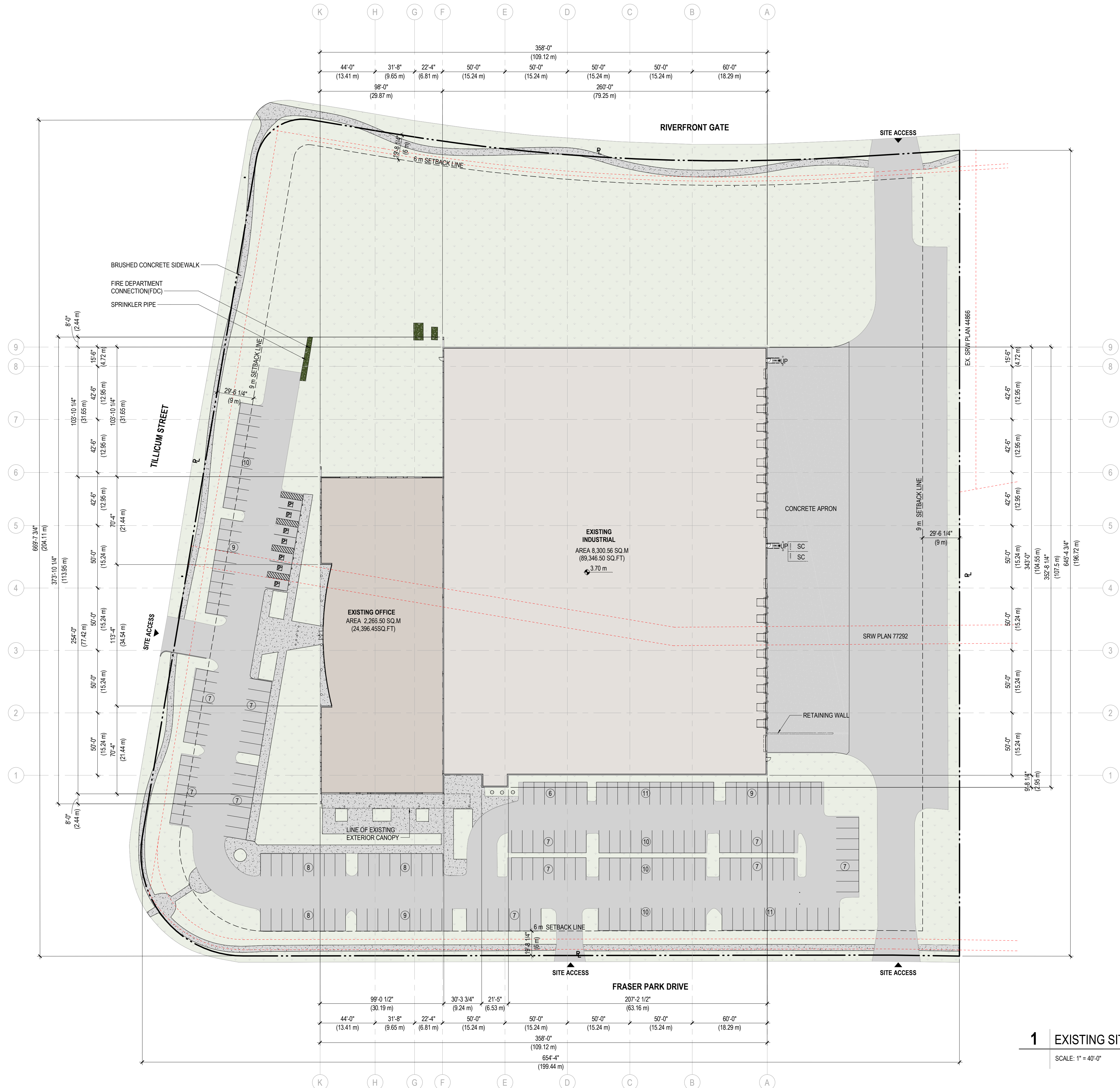

**SITE DATA**

**GENERAL INFORMATION**

<b>CIVIC ADDRESS:</b>	4560 TILlicum STREET, BURNABY, BC
<b>LEGAL ADDRESS:</b>	LOT 3 DISTRICT LOT 166, GROUP 1, NEW WESTMINSTER DISTRICT PLAN LMP42789
<b>BUILDING USE:</b>	LIGHT INDUSTRIAL
<b>EXISTING BUILDING AREA:</b>	10,567.10 m <sup>2</sup> 113,742.90 ft <sup>2</sup>
<b>ZONING:</b>	CD / M5
<b>SITE AREA:</b>	36,793.92 m <sup>2</sup> 3.68 hectare 396,046.50 ft <sup>2</sup> 9.09 acres
<b>BUILDING HEIGHT:</b>	13.40 M (44'-1")
<b>EXISTING PARKING SPACE:</b>	
	STANDARD PARKING 199
	ACCESSIBLE PARKING 7
	TOTAL PARKING: 206
<b>TOTAL EXISTING LOADING DOCK / GRADE DOOR:</b>	19

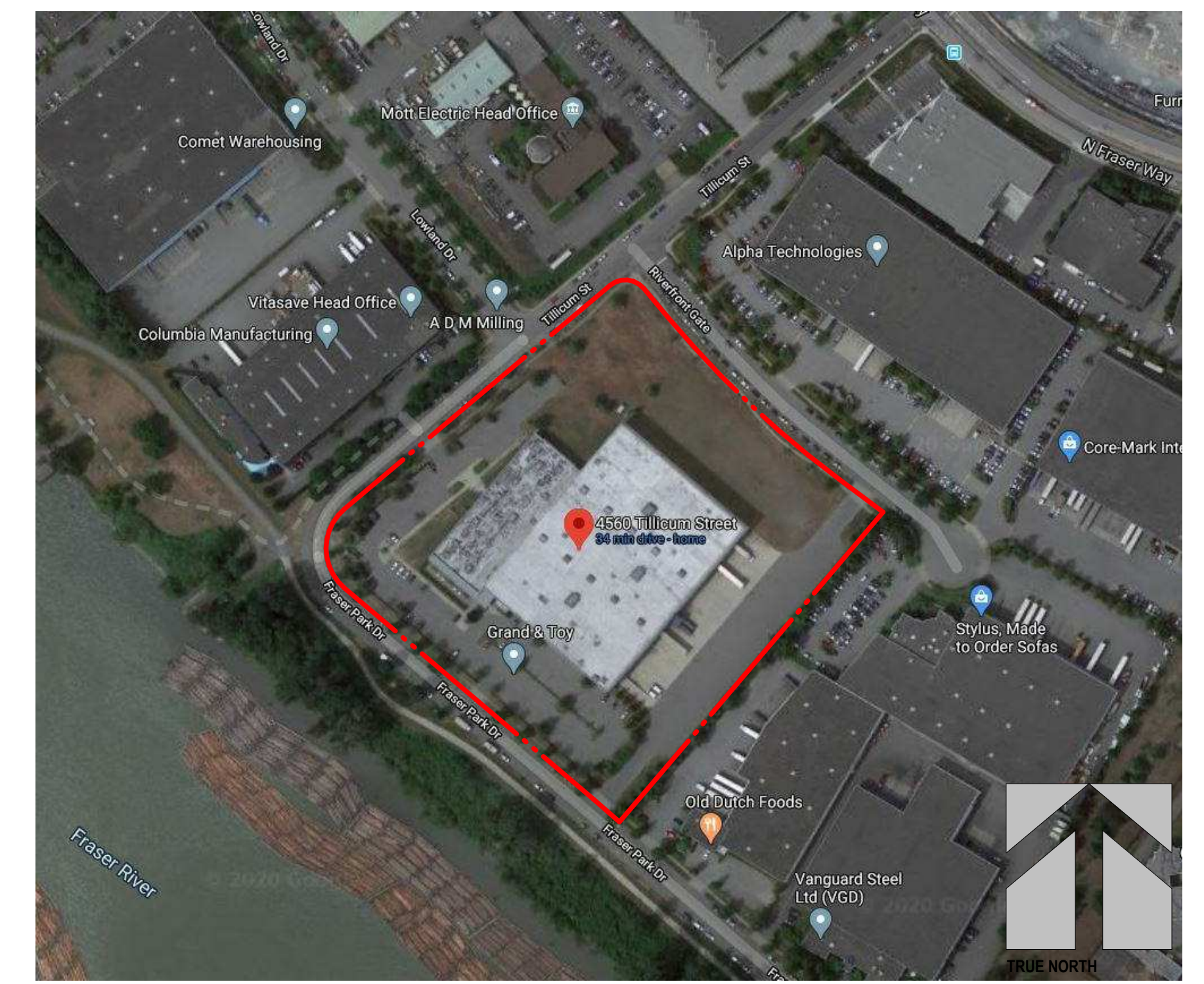

**2 CONTEXT PLAN**

SCALE: 1" = 200'-0"

**1 EXISTING SITE PLAN**

SCALE: 1" = 40'-0"

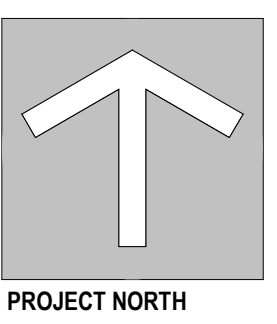



**REZONING # 19-71**

**GENERAL INFORMATION**

**CIVIC ADDRESS:** 4560 TILLICUM STREET, BURNABY, BC  
**LEGAL ADDRESS:** LOT 3 DISTRICT LOT 166, GROUP 1, NEW WESTMINSTER DISTRICT PLAN LMP42789  
**ZONING:** CD / M5  
**MAIN SITE AREA:** 36,793.92 m<sup>2</sup> | 3.68 hectare | 396,046.50 ft<sup>2</sup> | 9.09 acres

**TOTAL SITE AREA AND SUBDIVISIONS:**

NAME	AREA (SQ M)	AREA (HECTARE)	AREA (SQ FT)	AREA (ACRES)
ROAD DEDICATION	270.71	0.03	2,913.86	0.07
SUBDIVISION-A	8,148.00	0.81	87,704.40	2.01
SUBDIVISION-B	28,375.21	2.84	305,428.22	7.01
<b>TOTAL LOT AREA</b>	<b>36,793.92</b>	<b>3.68</b>	<b>396,046.49</b>	<b>9.09</b>

**REZONING REQUIREMENTS:**  
 TO PROVIDE 1.5 M (4'-11") ROAD DEDICATION ALONG FRASER PARK DRIVE.

**1 SUBDIVISION PLAN**  
 SCALE: 1" = 40'-0"

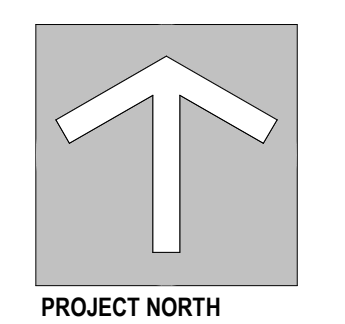



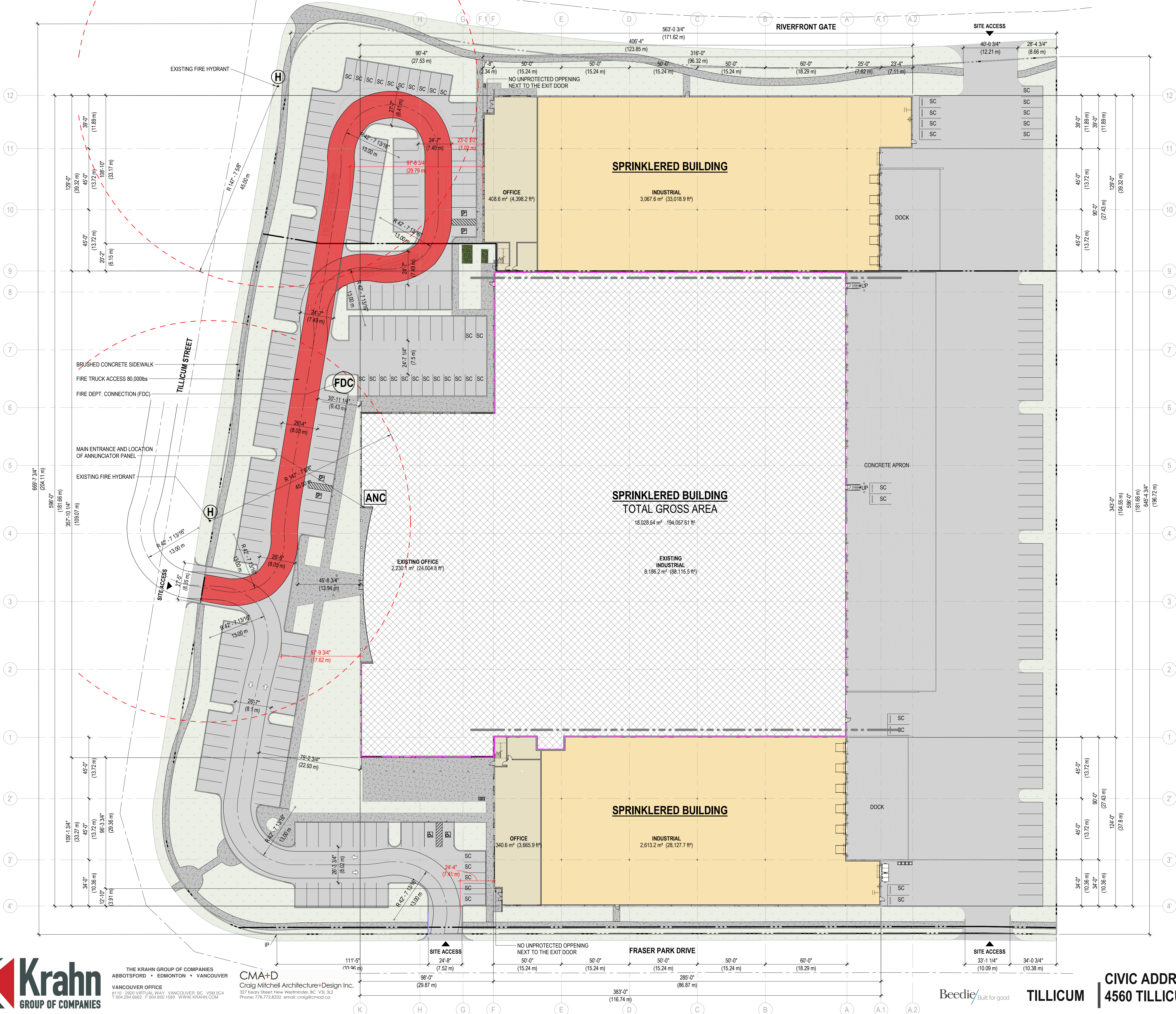

NOTE: FIRE TRUCK ACCESS ROUTE IS DESIGNED TO BURNABY'S SPECIFICATIONS.

- LEGEND**
- FIRE DEPARTMENT CONNECTION
  - FIRE HYDRANT
  - ANNUNCIATOR

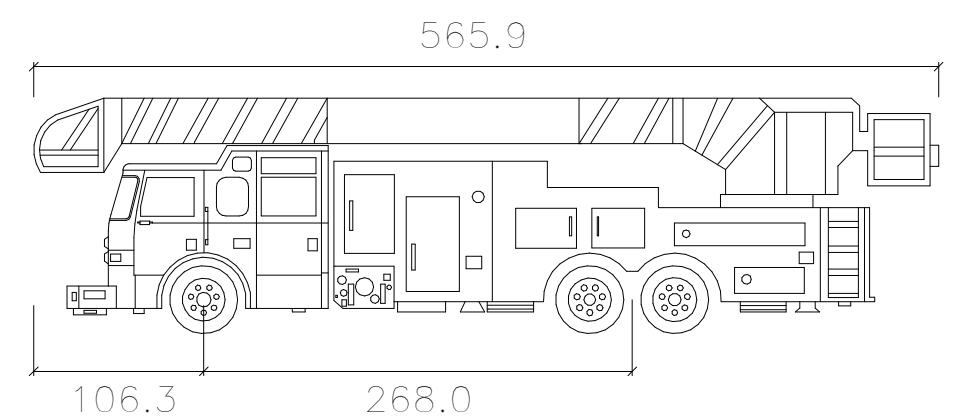

**Pierce Arrow XT**

WIDTH	96.1 INCHES
TRACK	96.1 INCHES
LOCK TO LOCK TIME	6.0
STEERING ANGLE	45.5°

**2 FIRE TRUCK PROFILE**

SCALE: 1" = 10'-0"

**1 FIRE-TRUCK ACCESS PLAN**

SCALE: 1/32" = 1'-0"

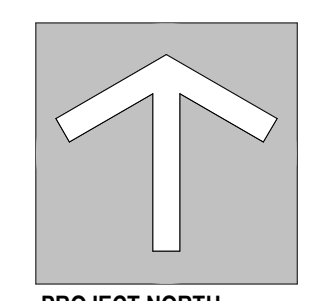

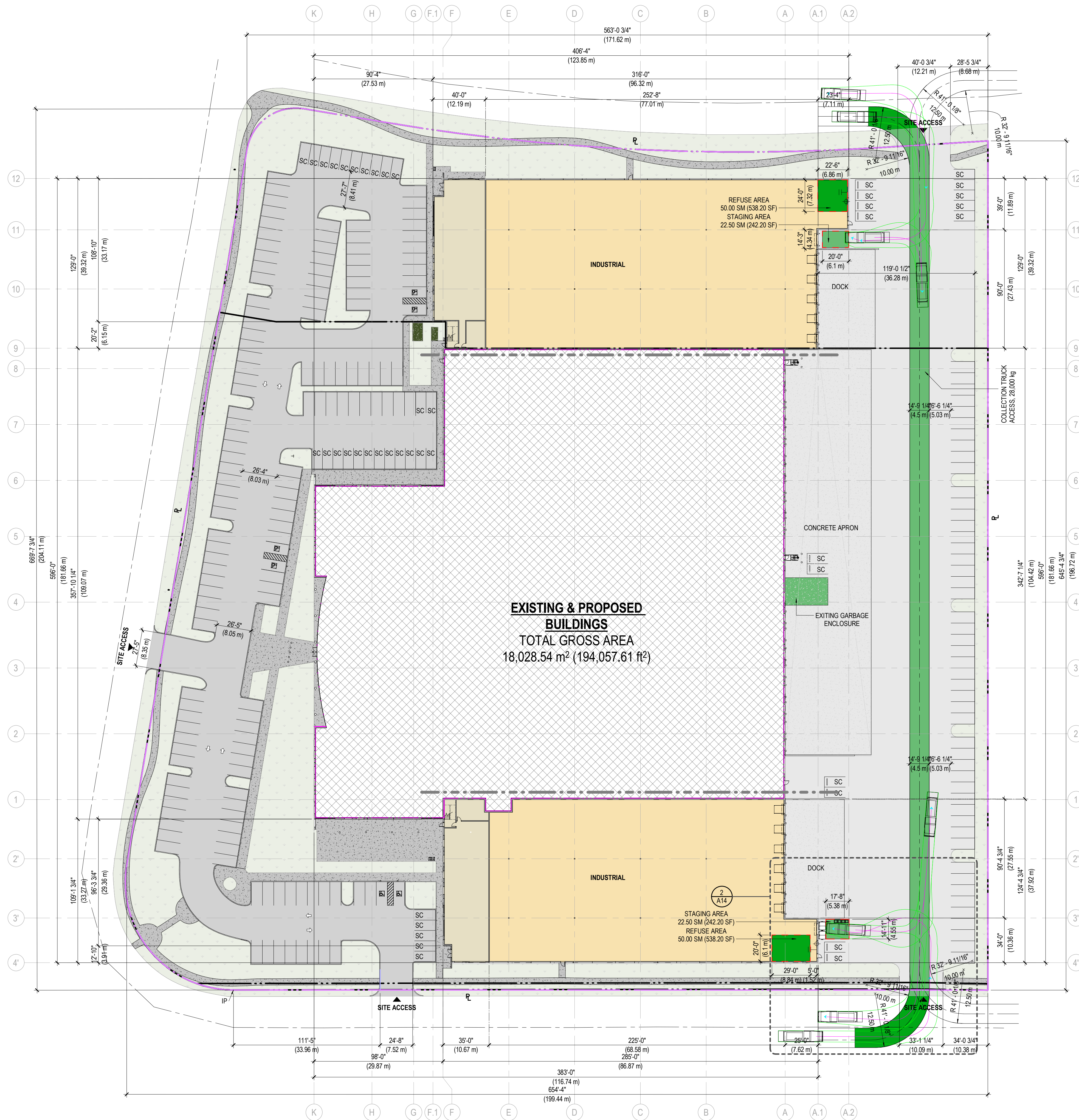

**1 REFUSE COLLECTION TRUCK TURNING PLAN**

SCALE: 1" = 40'-0"

**REQUIREMENTS**

REFUSE STORAGE FACILITY			
NAME	AREA (SM)	RATE PER SM	REQ. AREA SM
EXP. AREA "A" GROUND FLOOR OFFICE	453.62	0.008	3.63
EXP. AREA "A" MEZZANINE OFFICE	446.92	0.008	3.58
EXP. AREA "B" GROUND FLOOR OFFICE	391.28	0.008	3.13
EXP. AREA "B" MEZZANINE OFFICE	387.44	0.008	3.10
EXP. AREA "A" GROUND FLOOR INDUSTRIAL	3,115.04	0.018	56.07
EXP. AREA "B" GROUND FLOOR INDUSTRIAL	2,854.95	0.018	47.79
TOTAL WASTE AREA	7,449.25		117.29

NOTE: MAXIMUM REQUIREMENT IS 100 SM.

**REQUIRED STAGING AREA:**

REQUIRED SPACE = REQUIRED REFUSE AREA x %45  
 EXPANSION AREA "A": 50.00 SM x %45=22.50 SM  
 EXPANSION AREA "B": 50.00 SM x %45=22.50 SM

**ABBREVIATION LEGEND**

TAG	DESCRIPTION
FD	FLOOR DRAIN
HB	HOSE BIB

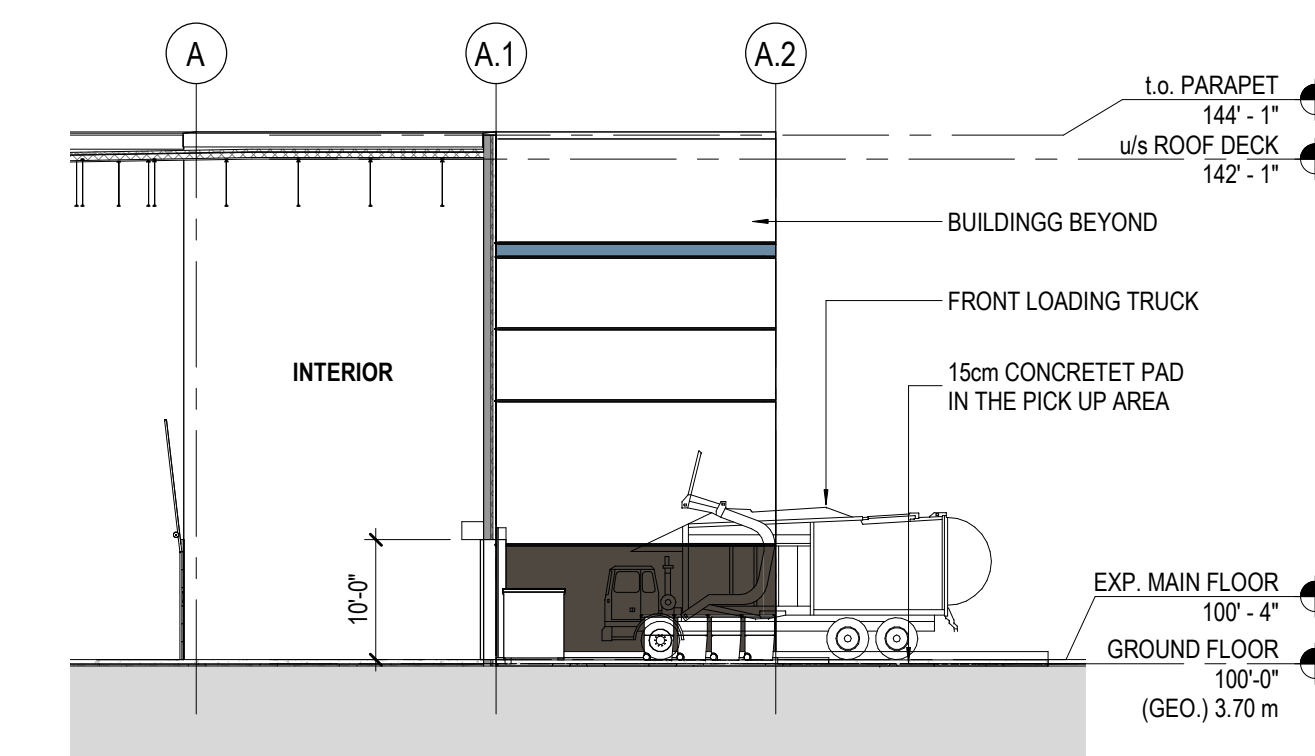

**3 REFUSE AREA ACCESS SECTION**

SCALE: 1/16" = 1'-0"

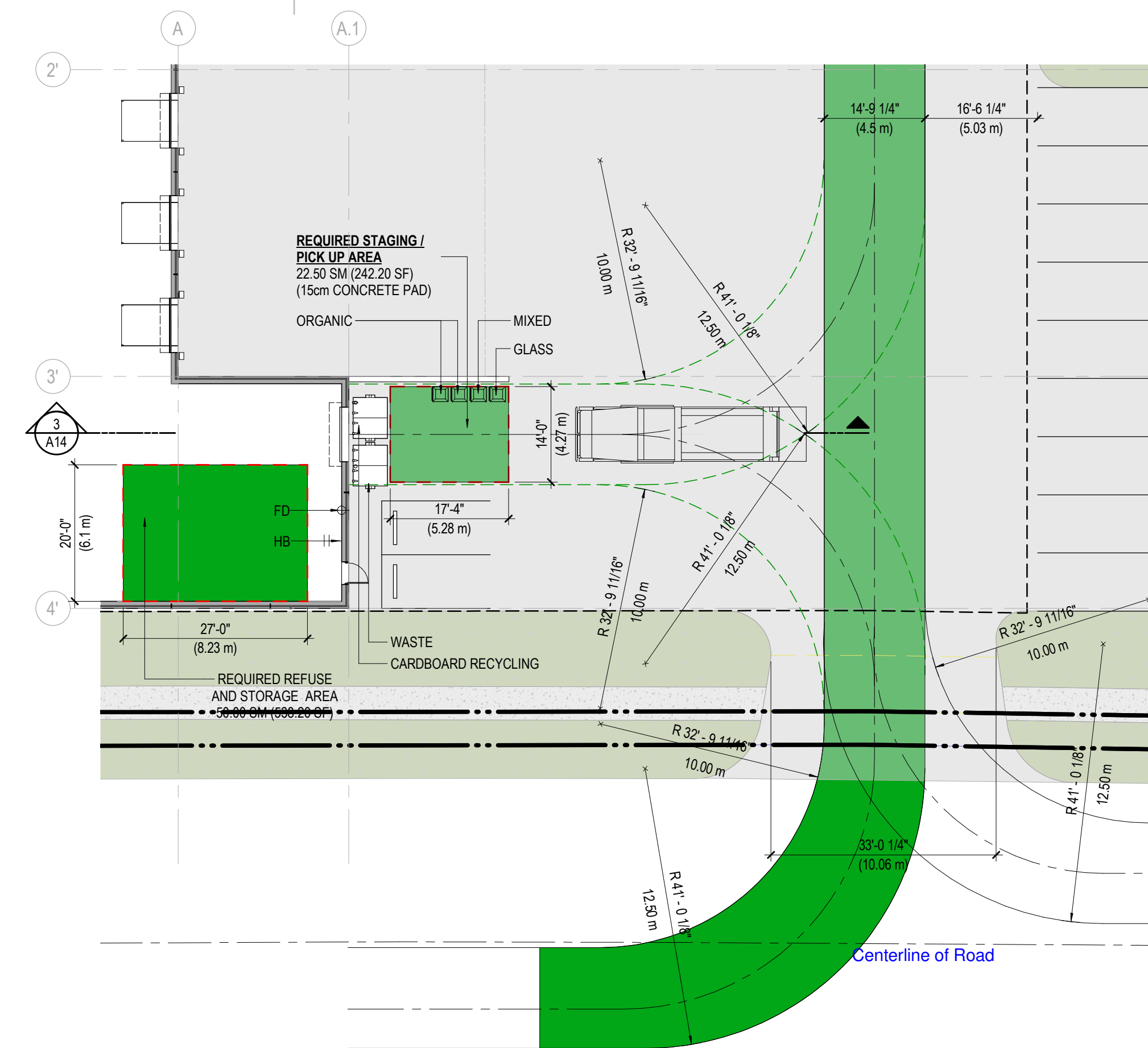

**2 FRONT-END LOADER REFUSE AREA ACCESS**

SCALE: 1/16" = 1'-0"

**GENERAL NOTES:**

- REFUSE STORAGE FACILITIES:**
- ALL REFUSE BINS TO BE STORED INSIDE TENANT WAREHOUSE DESIGNATED REFUSE AREA.
  - FLOOR DRAINS TO BE PROVIDED WITH CONNECTION TO SANITARY SEWER AND COMPLETE WITH GREASE INTERCEPTOR.
- STAGING / PICKUP AREA:**
- PROVIDE APPROPRIATE SLOPE TO FACILITATE DRAINAGE TO DESIGNATED STORMWATER MANAGEMENT SYSTEM.
  - MAXIMUM SLOPE TO STAGING AREA NOT TO EXCEED 6%.
- COLLECTION ROUTE:**
- DRIVING SURFACE TO ACCOMMODATE 28 TONNE VEHICLE.
  - ACCOMMODATE CONTAINER PICKUP FROM FRONT SIDE LOADING.
  - MINIMUM 6.0m WIDTH AT SITE ACCESS DRIVEWAYS.
  - MINIMUM 4.5m ONSITE ROUTE WIDTH.
  - MINIMUM 10.0m INSIDE TURNING RADIUS.
  - MINIMUM 12.5m OUTSIDE TURNING RADIUS.
  - MINIMUM 4.4m VERTICAL CLEARANCE.

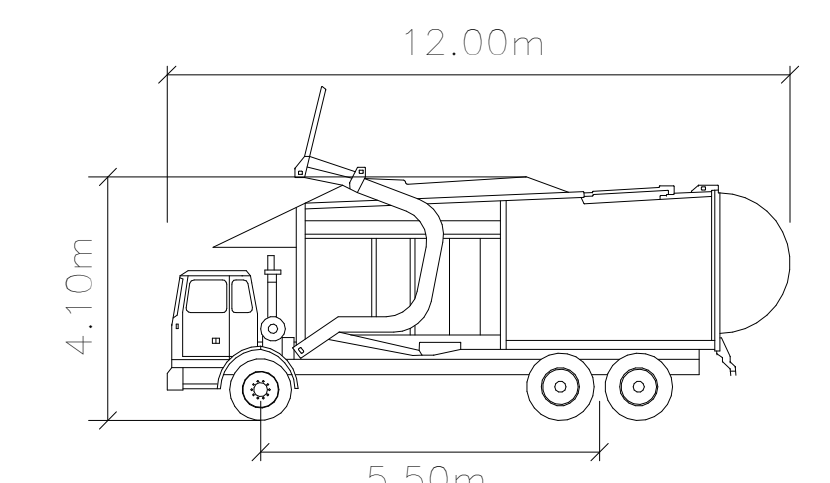

**FRONT LOADING TRUCK**

meter

Width : 2.40  
 Approximate weight fully loaded : 28,000 kg  
 Outside turning radius : 12.50  
 Inside turning radius : 10.50

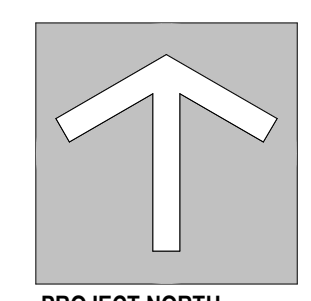

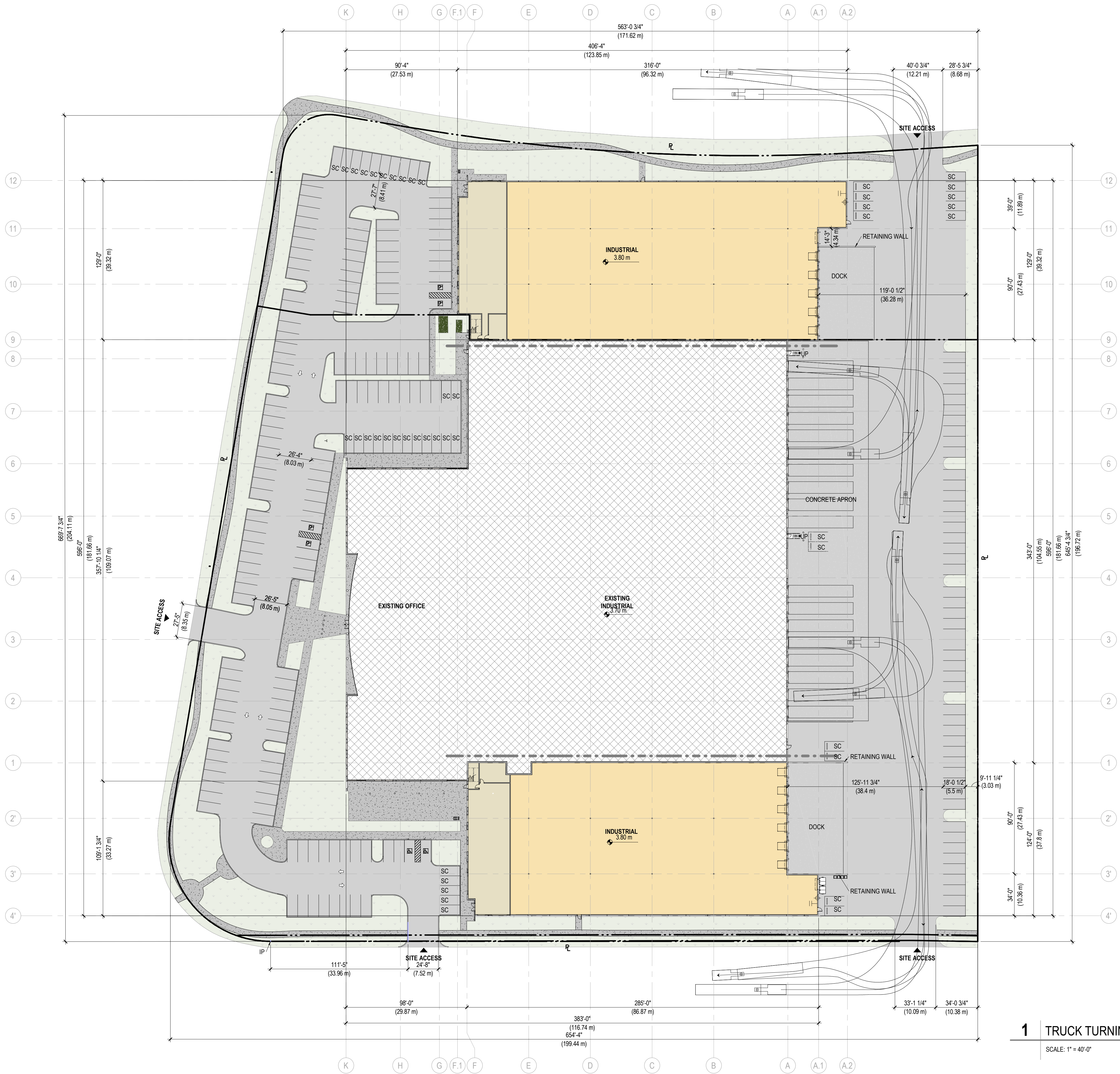

**1 TRUCK TURNING PLAN**  
SCALE: 1" = 40'-0"

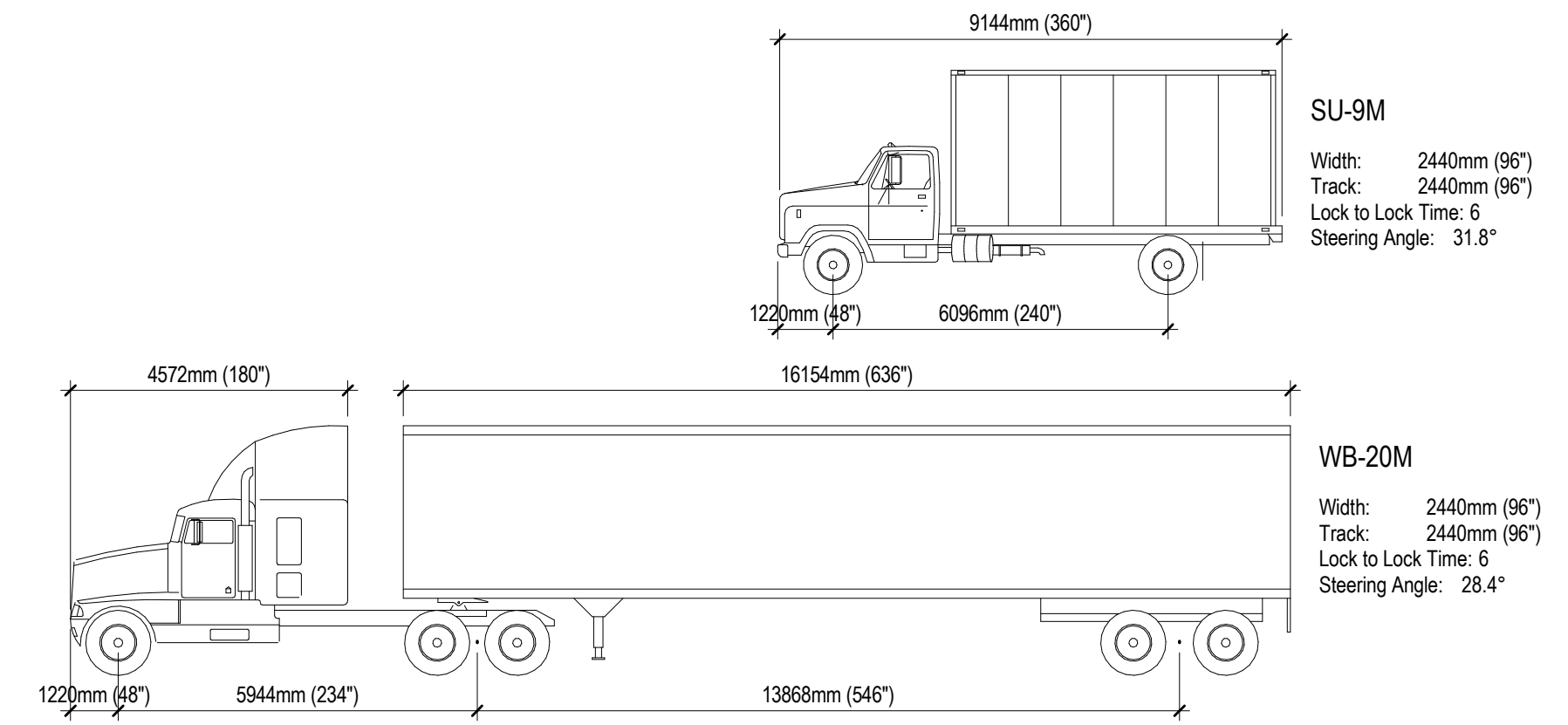

**2 TRUCK PROFILES**  
SCALE: 1" = 10'-0"

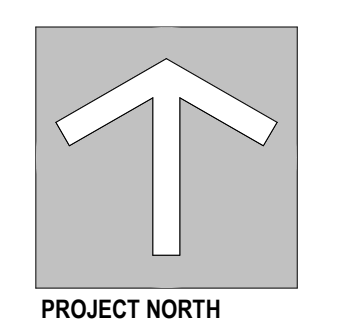



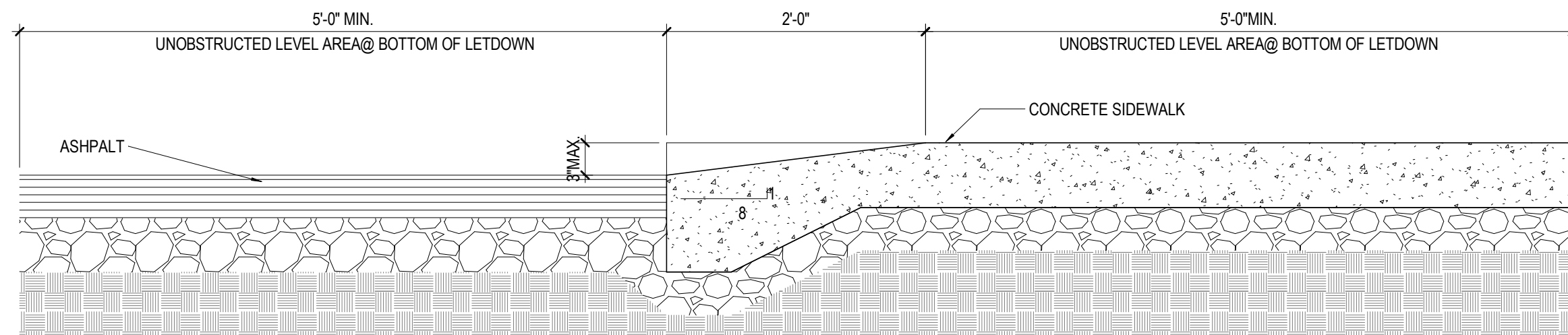
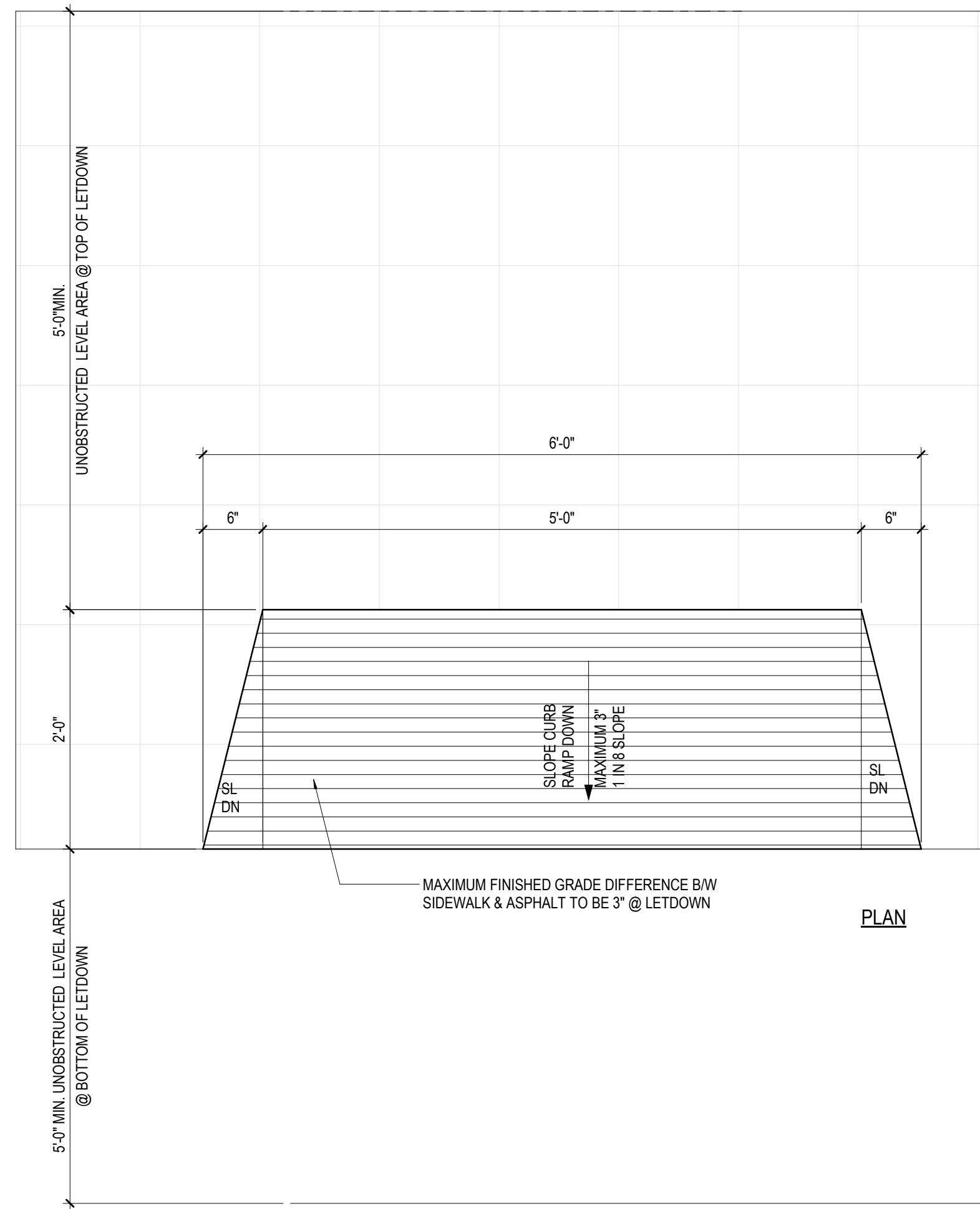

SECTION

**1** HC LETDOWN/CURB RAMP

SCALE: 1" = 1'-0"

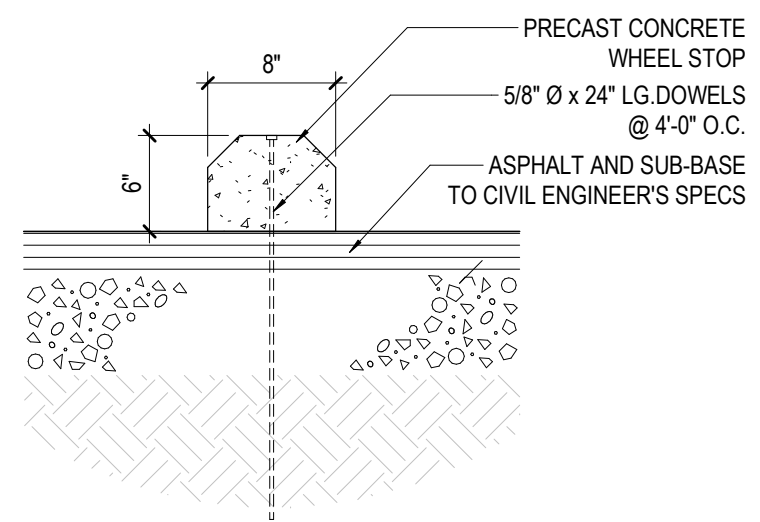

**5** CONCRETE WHEEL STOP

SCALE: 1" = 1'-0"

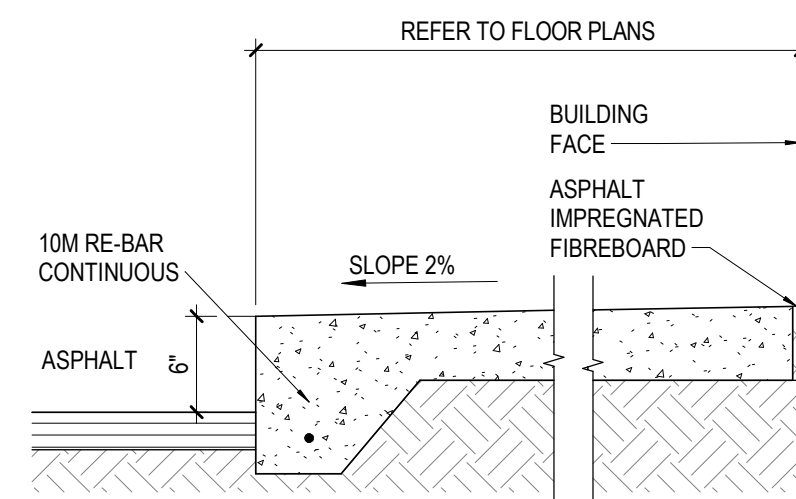

**6** SIDEWALK EDGE DETAIL

SCALE: 1" = 1'-0"

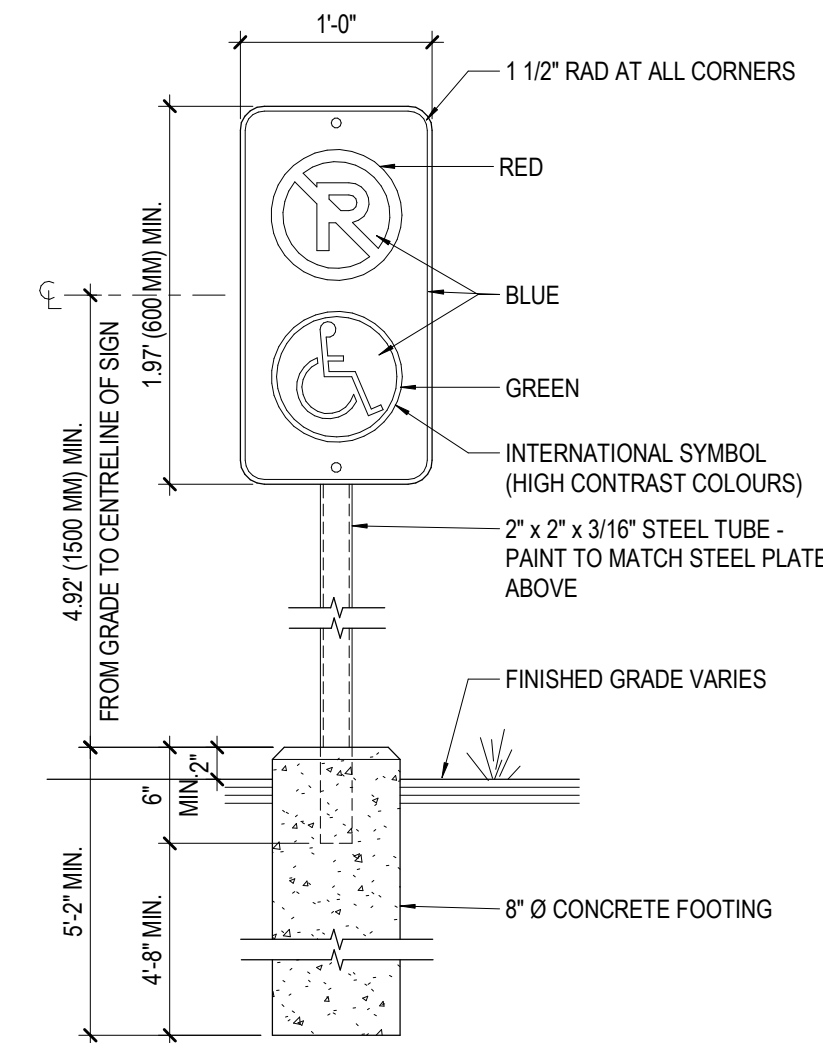

**NOTE:**

1. SIGN SHOULD BE PROPERLY CENTERED AT FRONT OF PARKING SPACE.
2. SIGN FACE SHOULD BE LOCATED NO FURTHER THAN 6" FROM THE FRONT OF EACH PARKING SPACE WITH A MINIMUM 3'-0" CLEAR.
3. MOUNT SIGN ON COLUMN OR WALL AT SIM. CONDITION
4. WHERE SIGN IS PLACED IN PAVED AREA AT PARKING STALLS, PROVIDE PRE-CAST BUMPERS

**2** ACCESSIBLE POST MOUNTED SIGN

SCALE: 1" = 1'-0"

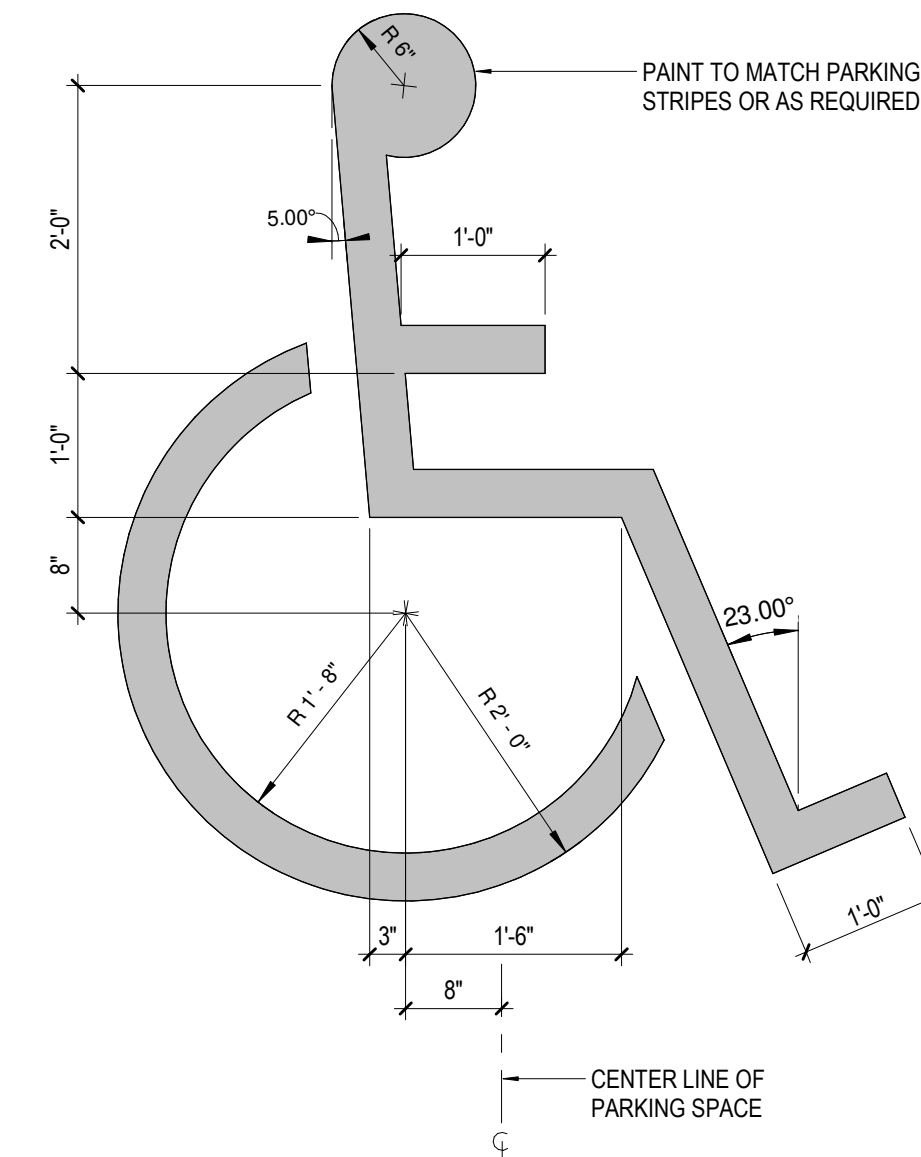

**3** ACCESSIBLE PAINTED SYMBOL

SCALE: 3/4" = 1'-0"

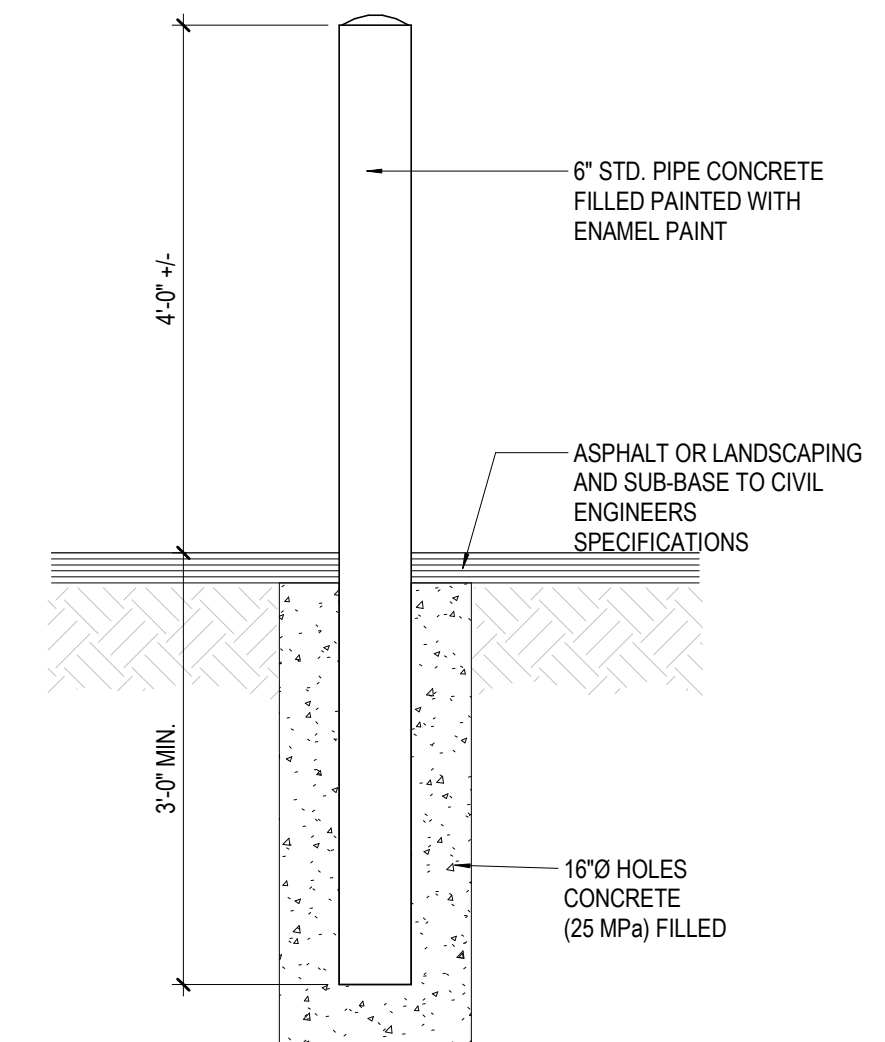

**4** EXTERIOR BOLLARD

SCALE: 1 1/2" = 1'-0"

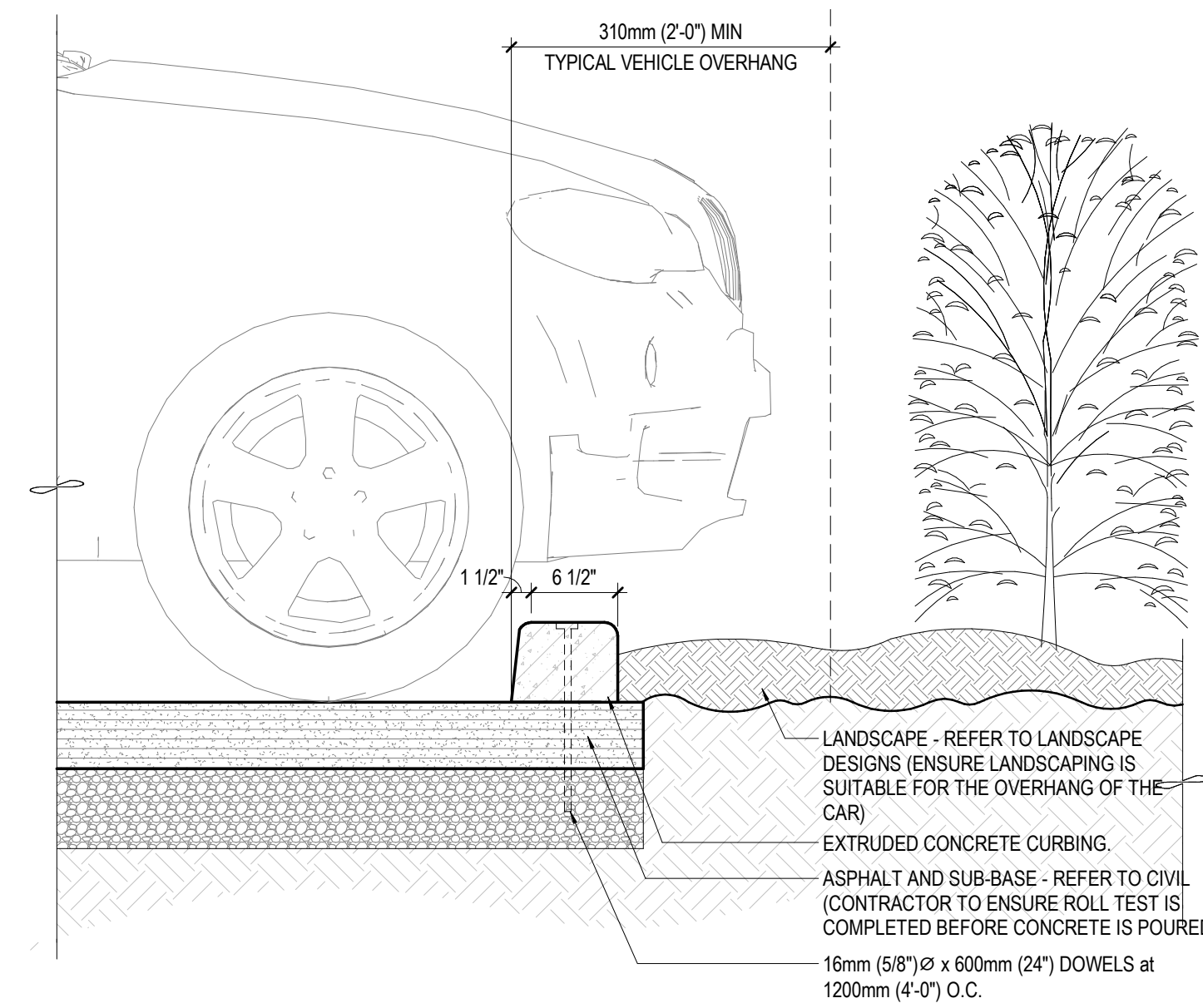

**7** CONCRETE CURB - CAR OVERHANG LANDSCAPE

SCALE: 1" = 1'-0"

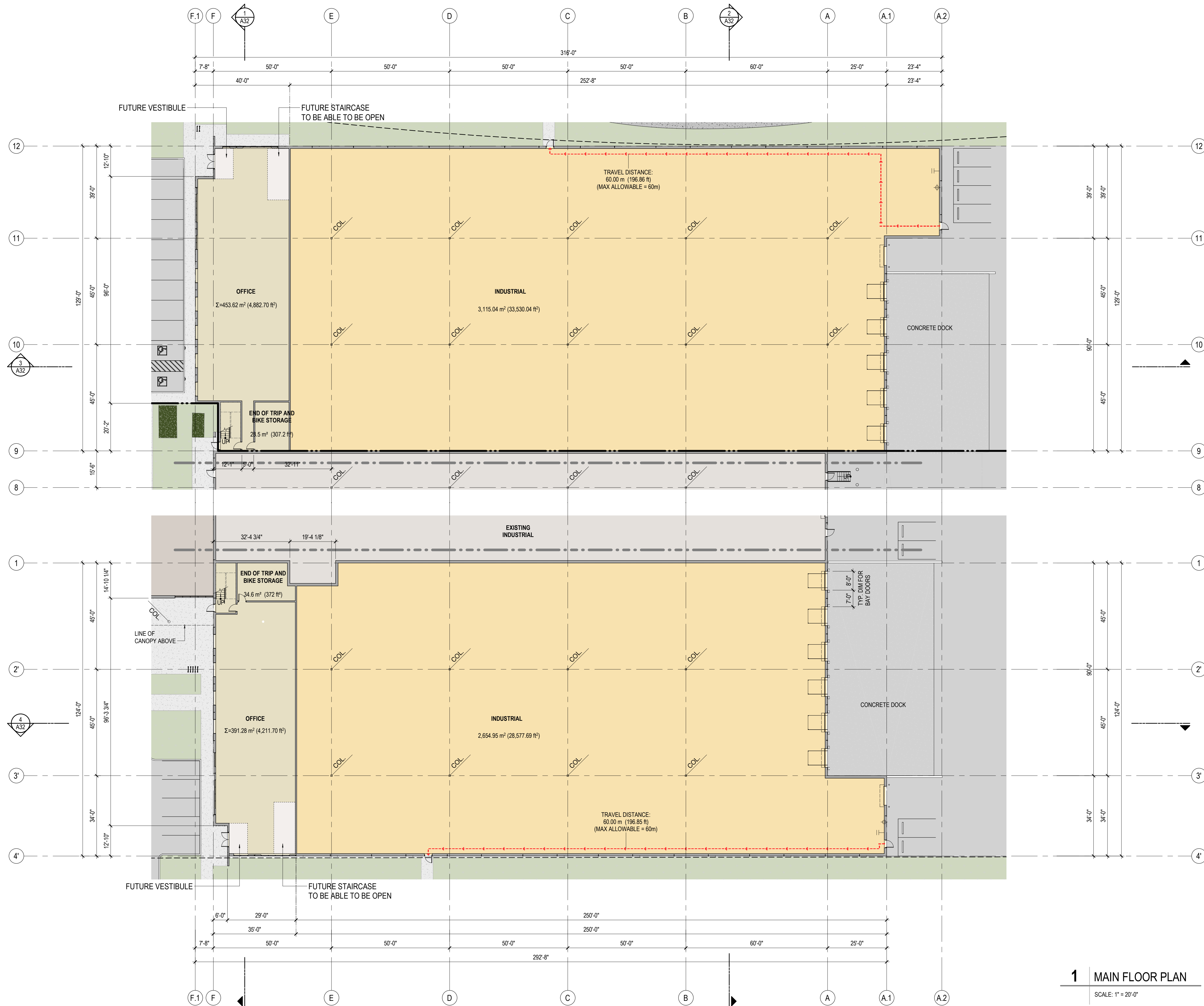

**1 MAIN FLOOR PLAN**  
SCALE: 1" = 20'-0"

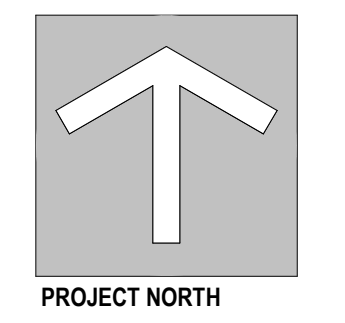
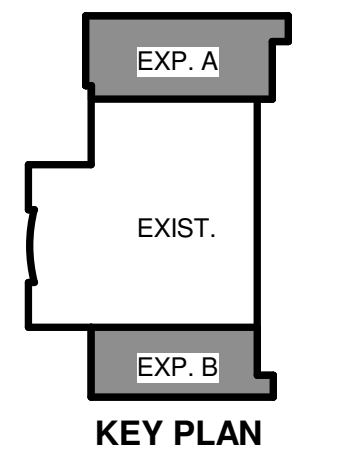

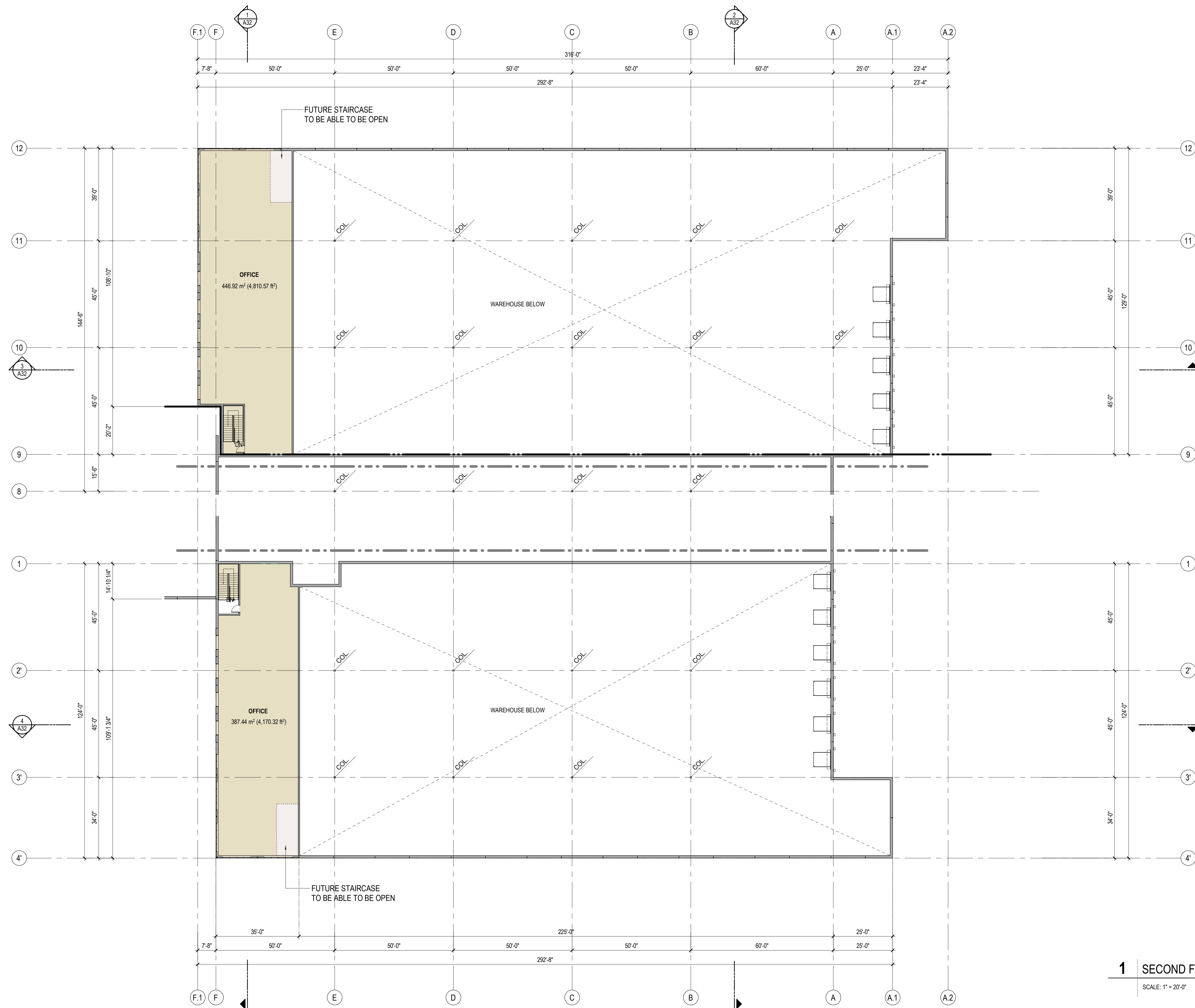

**1 SECOND FLOOR PLAN**  
SCALE: 1" = 20'-0"

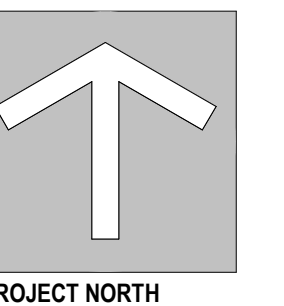





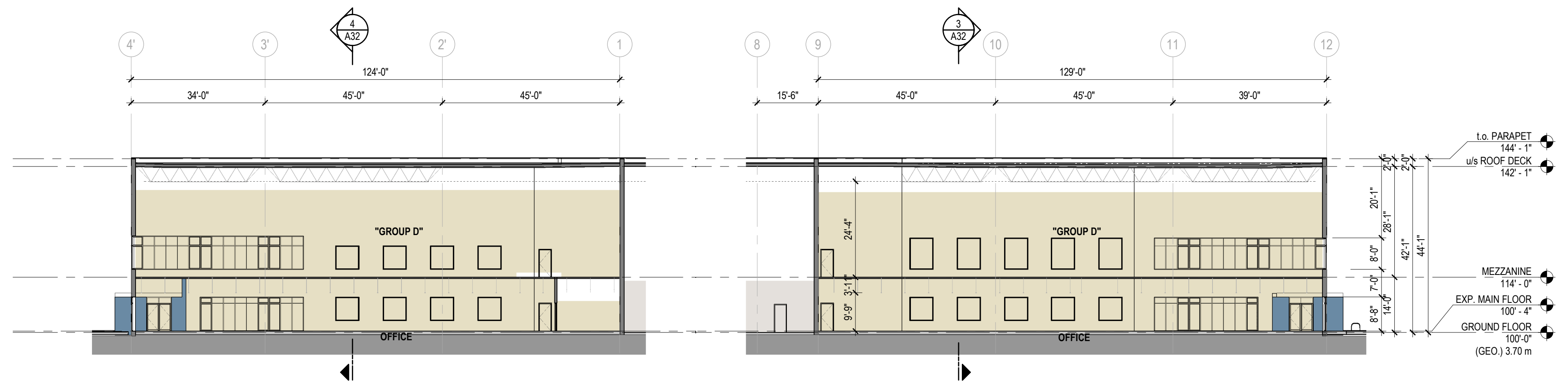

**1 SECTION 1**  
SCALE: 1" = 20'-0"

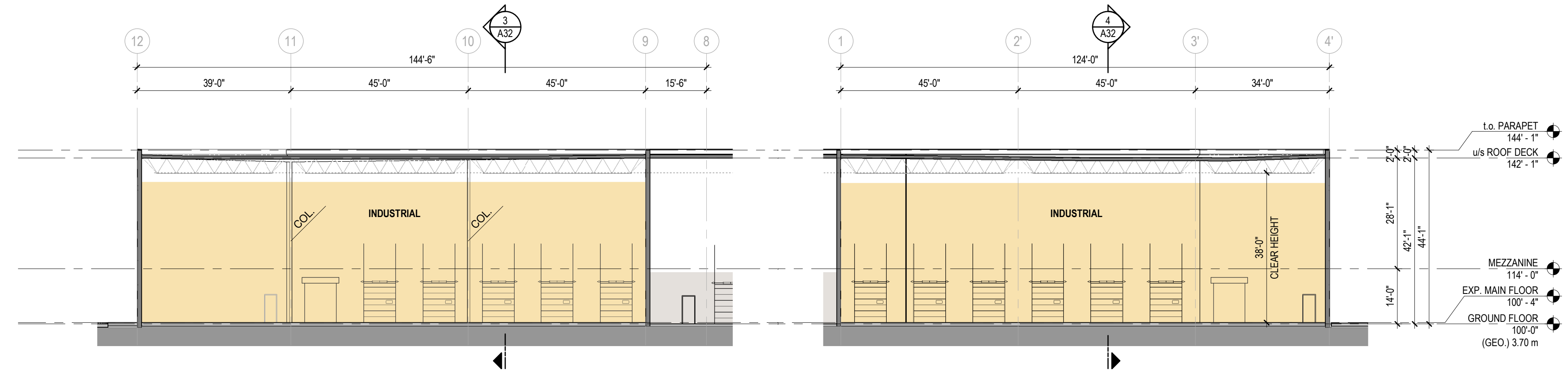

**2 SECTION 2**  
SCALE: 1" = 20'-0"

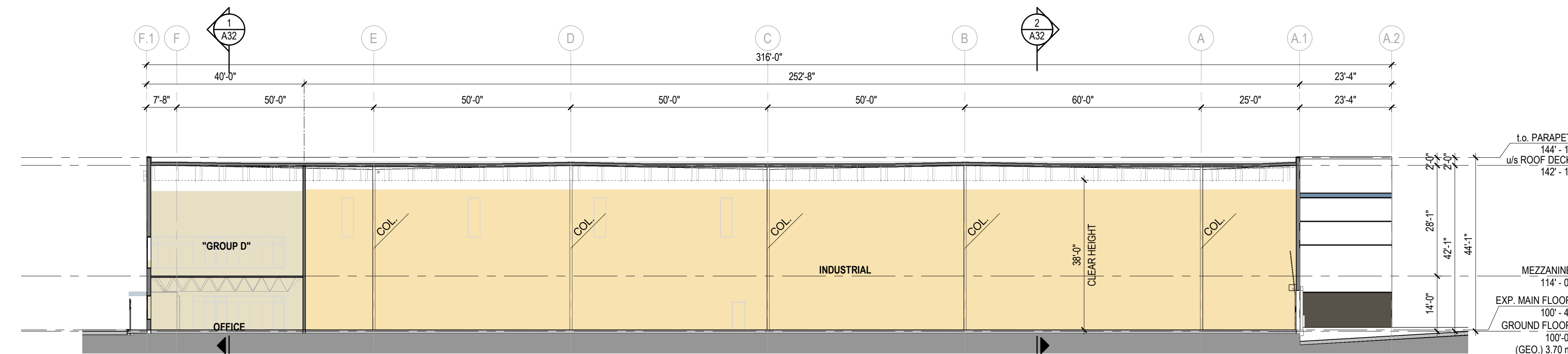

**3 SECTION 3**  
SCALE: 1" = 20'-0"

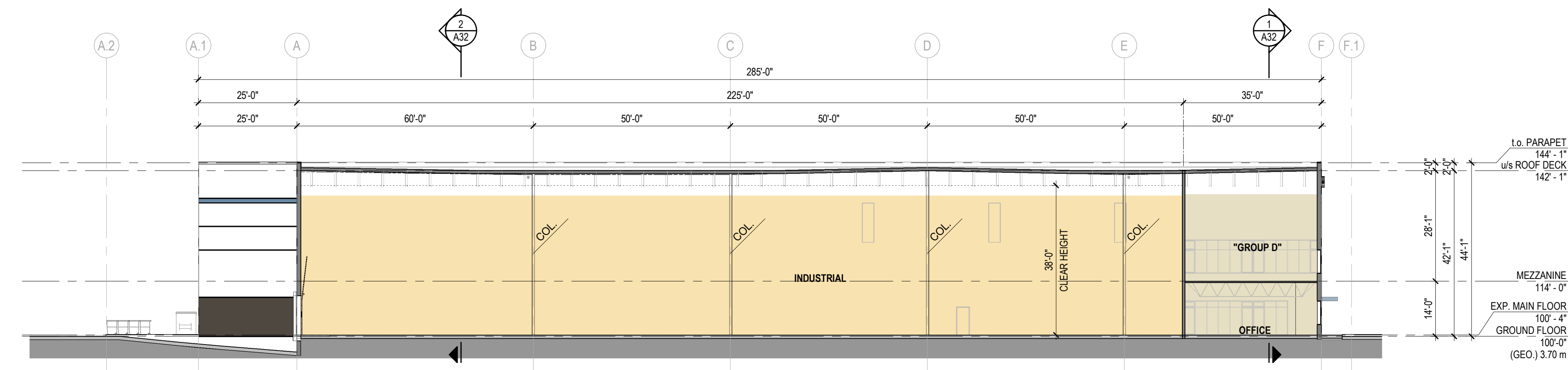

**4 SECTION 4**  
SCALE: 1" = 20'-0"