

CITY OF BURNABY

BYLAW NO. 14519

A BYLAW to close
a certain portion of highway

WHEREAS pursuant to section 40 of the *Community Charter* the Council may by bylaw close part of a highway to traffic;

AND WHEREAS the Council, before adopting this Bylaw, has caused the required statutory public notice of its intention to be given by advertisement;

AND WHEREAS the Council deems it expedient and in the public interest to stop up and close to traffic that portion of highway more particularly hereinafter described;

NOW THEREFORE the Council of the City of Burnaby ENACTS as follows:

1. This Bylaw may be cited as **BURNABY HIGHWAY CLOSURE BYLAW NO. 5, 2022.**

2. ALL AND SINGULAR that certain parcel or tract of land, situate, lying and being in the City of Burnaby, in the Province of British Columbia, more particularly known and described as all those portions of road in District Lot 78, Group 1, New Westminster District, dedicated by Plan 3049, containing 0.202ha and District Lot 77, Group 1, New Westminster District, dedicated by Plan 3051, containing 0.231 ha (hereinafter called “the closed portions of road”) shown outlined on the Sketch Plan to accompany City of Burnaby Bylaw Number 14519, prepared by City of Burnaby, Engineering Department, a copy of which is hereunto annexed is hereby closed to all types of traffic.

Read a first time this	day of	, 2022
Read a second time this	day of	, 2022
Read a third time this	day of	, 2022
Reconsidered and adopted this	day of	, 2022

MAYOR

CLERK

**SKETCH PLAN TO ACCOMPANY CITY OF BURNABY
 BYLAW NUMBER 14519 TO CLOSE PART OF A ROAD
 DEDICATED ON PLAN 3049 OF DISTRICT LOT 78 AND
 PART OF ROAD DEDICATED ON PLAN 3051 OF
 DISTRICT LOT 77; ALL OF GROUP 1,
 NEW WESTMINSTER DISTRICT**

PURSUANT TO SECTION 40 OF THE COMMUNITY CHARTER

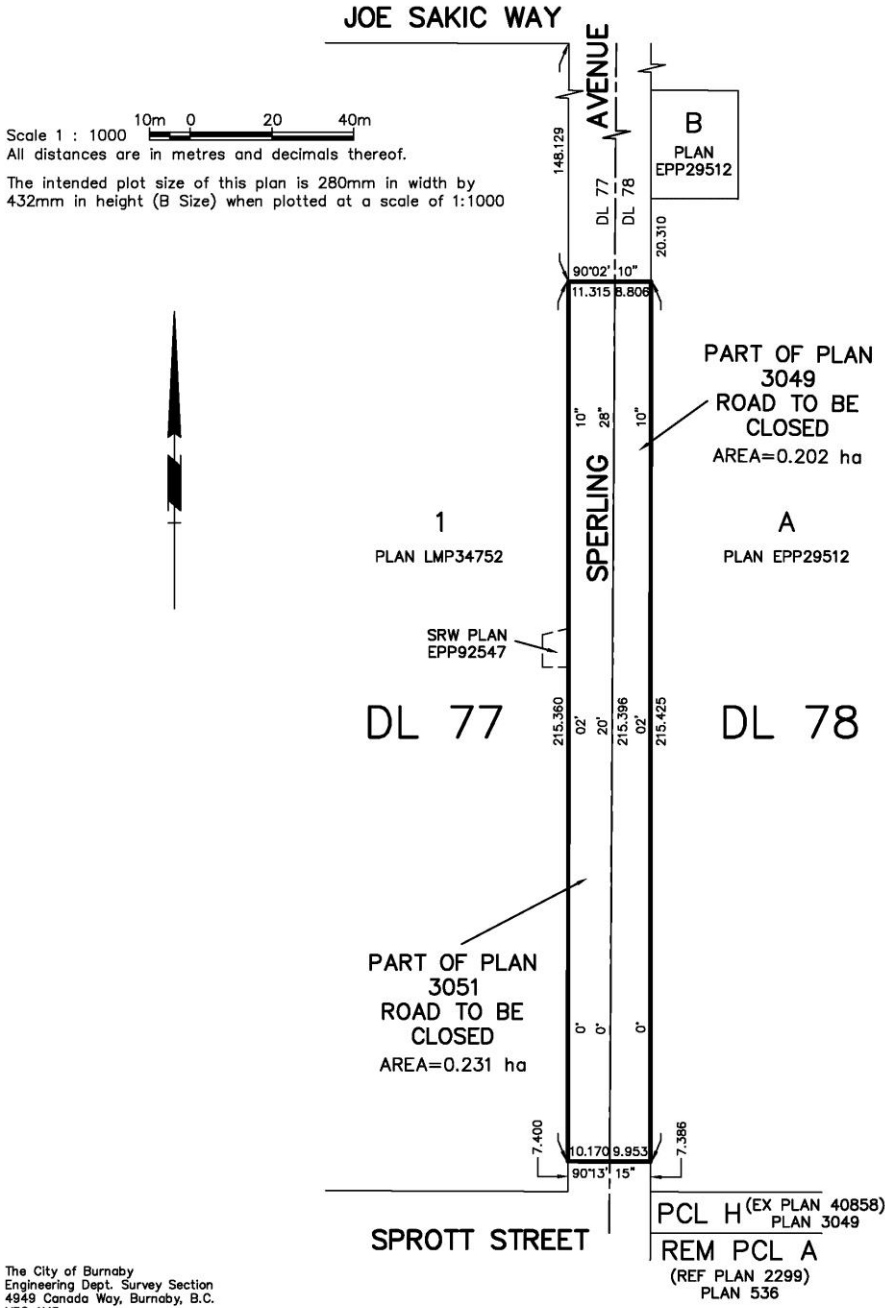

The City of Burnaby
 Engineering Dept. Survey Section
 4949 Canada Way, Burnaby, B.C.
 V5G 1M2
 Phone : (604) 294-7463
 Fax : (604) 294-7425